



# IEEE Standards & Ethernet

# IEEE STANDARDS

*In 1985, the Computer Society of the IEEE started a project, called Project 802, to set standards to enable intercommunication among equipment from a variety of manufacturers. Project 802 is a way of specifying functions of the physical layer and the data link layer of major LAN protocols.*

## OSI Model and Project 802

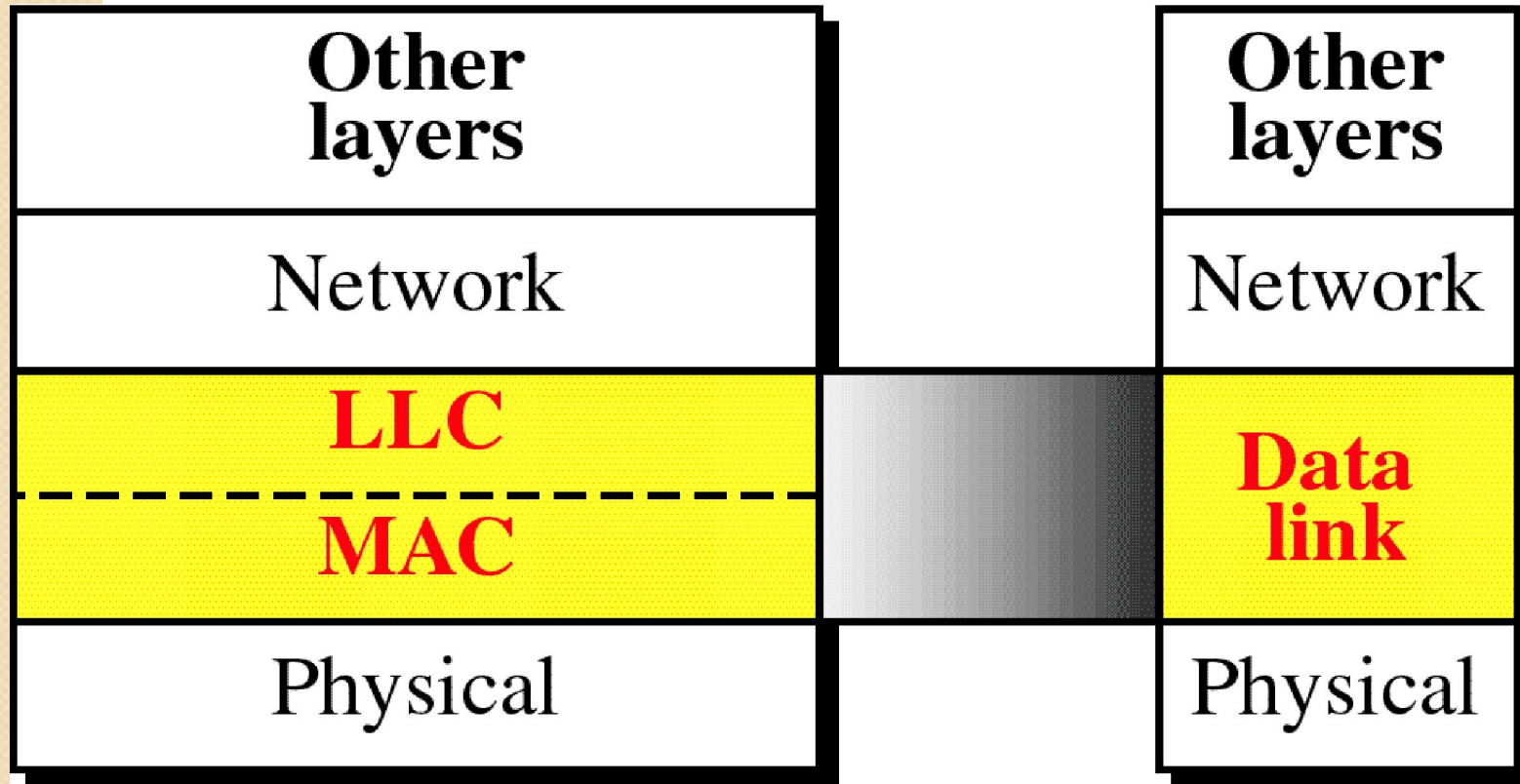

**Project 802**

**OSI Model**

## Project 802

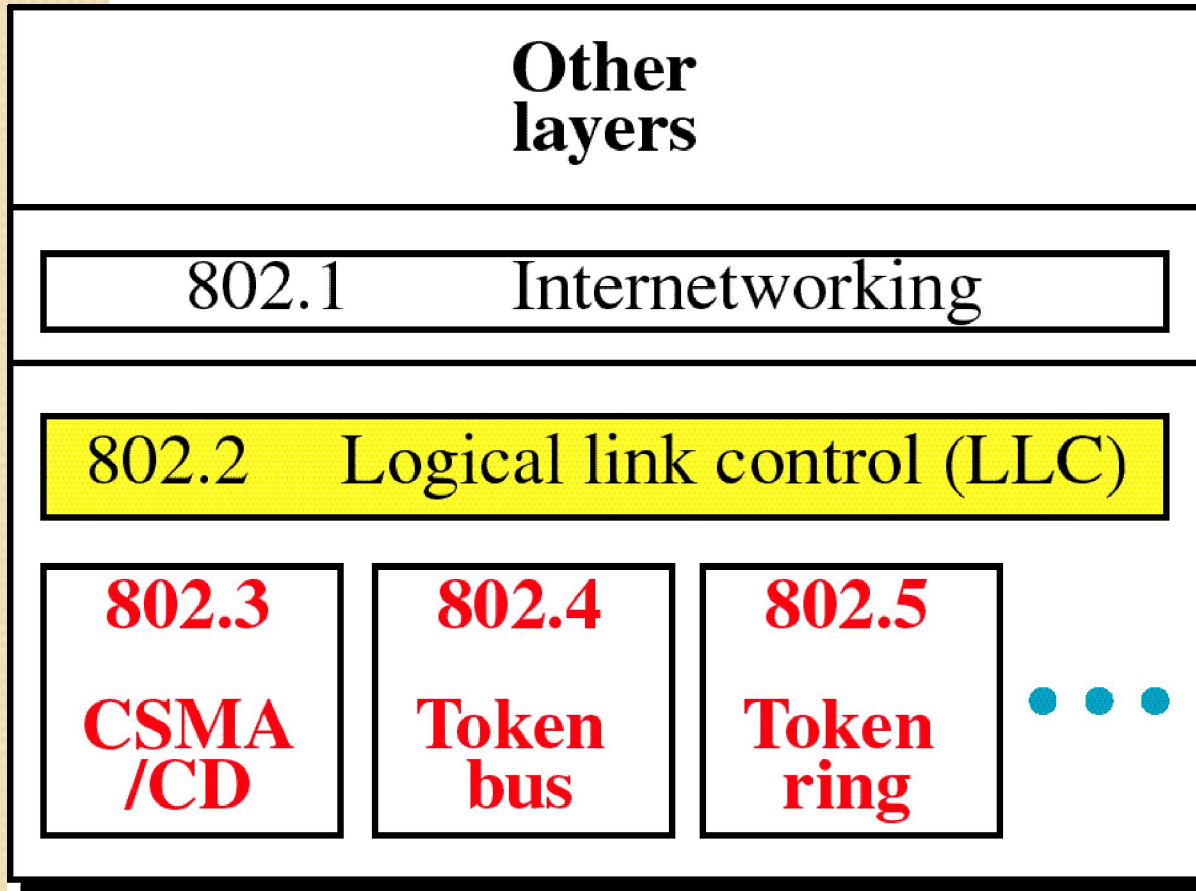

**Project 802**

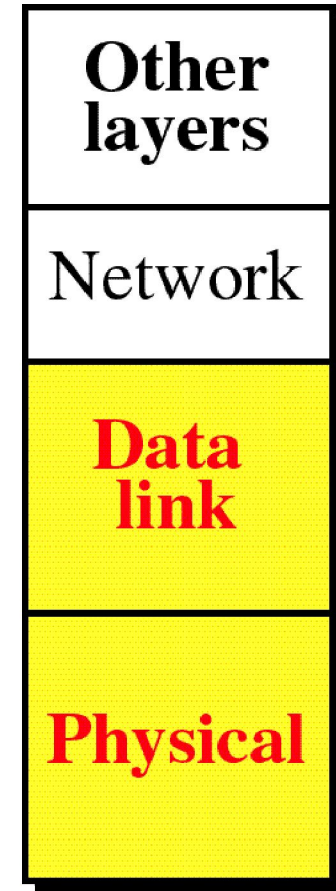

**OSI Model**

# IEEE standard for LANs

LLC: Logical link control  
MAC: Media access control

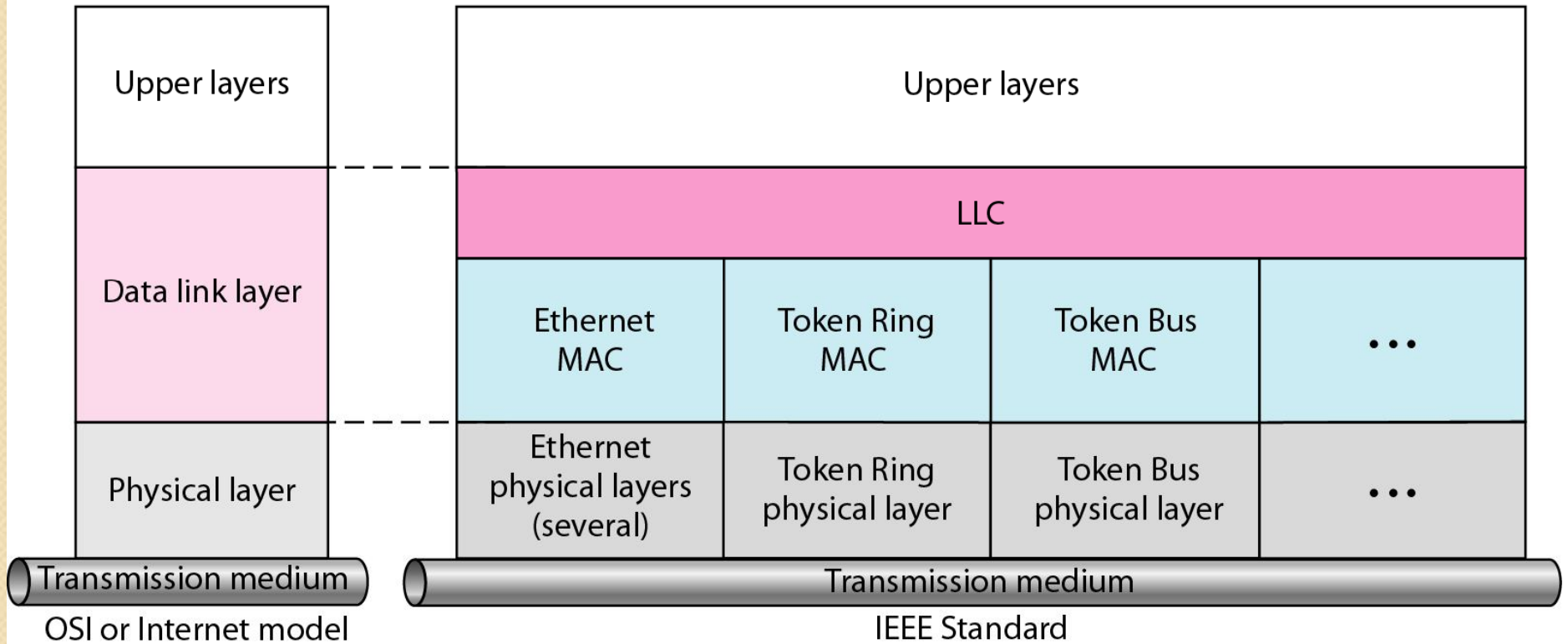

## IEEE 802 Standards

<b>802.1</b>	Bridging & Management
<b>802.2</b>	Logical Link Control
<b>802.3</b>	Ethernet - CSMA/CD Access Method
<b>802.4</b>	Token Passing Bus Access Method
<b>802.5</b>	Token Ring Access Method
<b>802.6</b>	Distributed Queue Dual Bus Access Method
<b>802.7</b>	Broadband LAN
<b>802.8</b>	Fiber Optic
<b>802.9</b>	Integrated Services LAN
<b>802.10</b>	Security
<b>802.11</b>	Wireless LAN
<b>802.12</b>	Demand Priority Access
<b>802.14</b>	Medium Access Control
<b>802.15</b>	Wireless Personal Area Networks
<b>802.16</b>	Broadband Wireless Metro Area Networks
<b>802.17</b>	Resilient Packet Ring

# STANDARD ETHERNET

*The original Ethernet was created in 1976 at Xerox's Palo Alto Research Center (PARC). Since then, it has gone through four generations.*

## Ethernet evolution through four generations

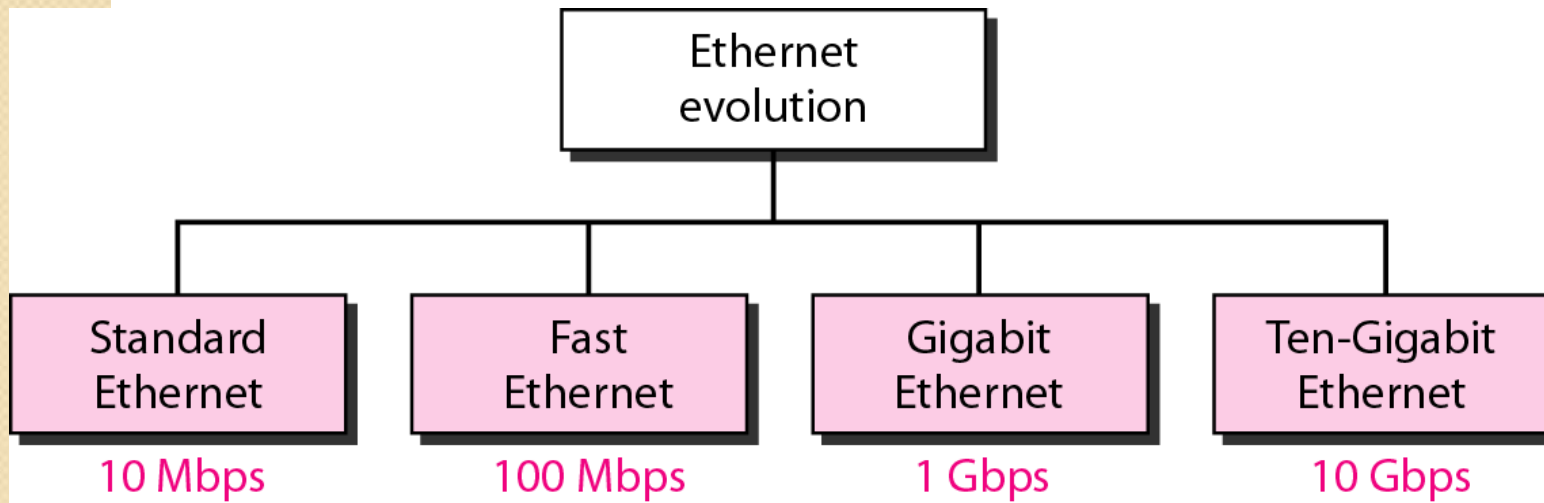



## 802.3 MAC frame

**Preamble:** 56 bits of alternating 1s and 0s.

**SFD:** Start frame delimiter, flag (10101011)

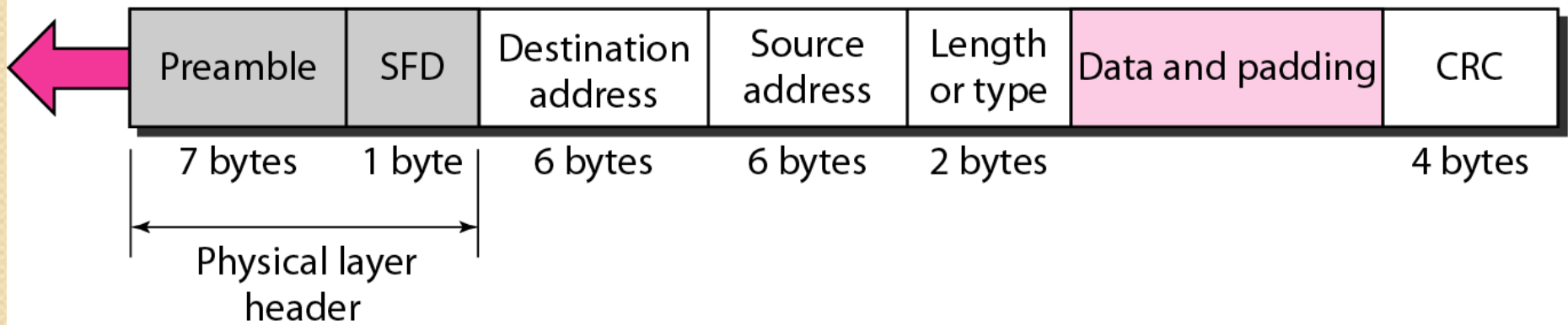

## Minimum and maximum lengths

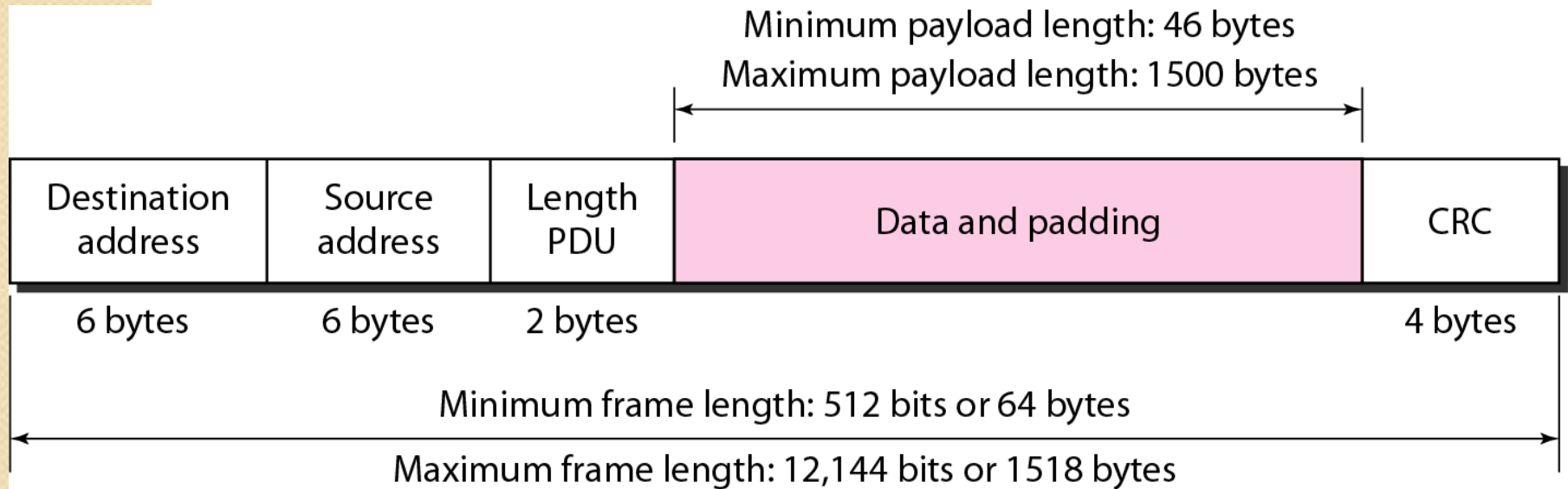



*Note*

Frame length:  
Minimum: 64 bytes (512 bits)  
Maximum: 1518 bytes (12,144 bits)

# Ethernet address/MAC address/Physical Address

- This address is the address of NIC itself
- NIC is from Network Interface Card or simply a network-card
- How does it look like ?

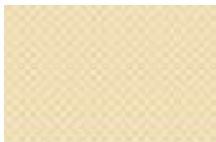
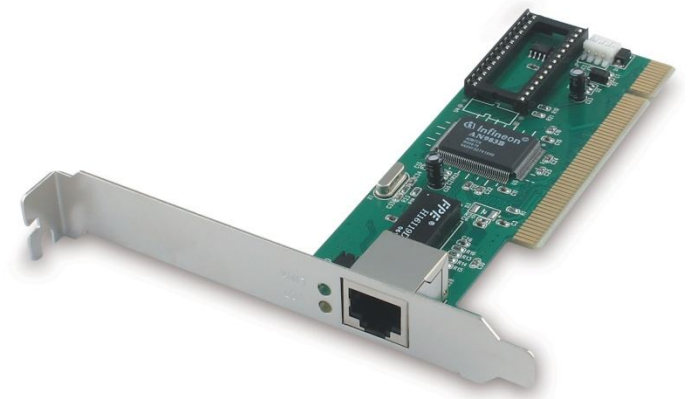

Success Amateur Blogger | This is a Personal Blog of Mine  
[PANGERAN.ORG](http://PANGERAN.ORG)



*How the address 47:20:1B:2E:08:EE is sent out on line.*

*The address is sent left-to-right, byte by byte; for each byte, it is sent right-to-left, bit by bit, as shown below:*

← 11100010 00000100 11011000 01110100 00010000 01110111

## Categories of Standard Ethernet

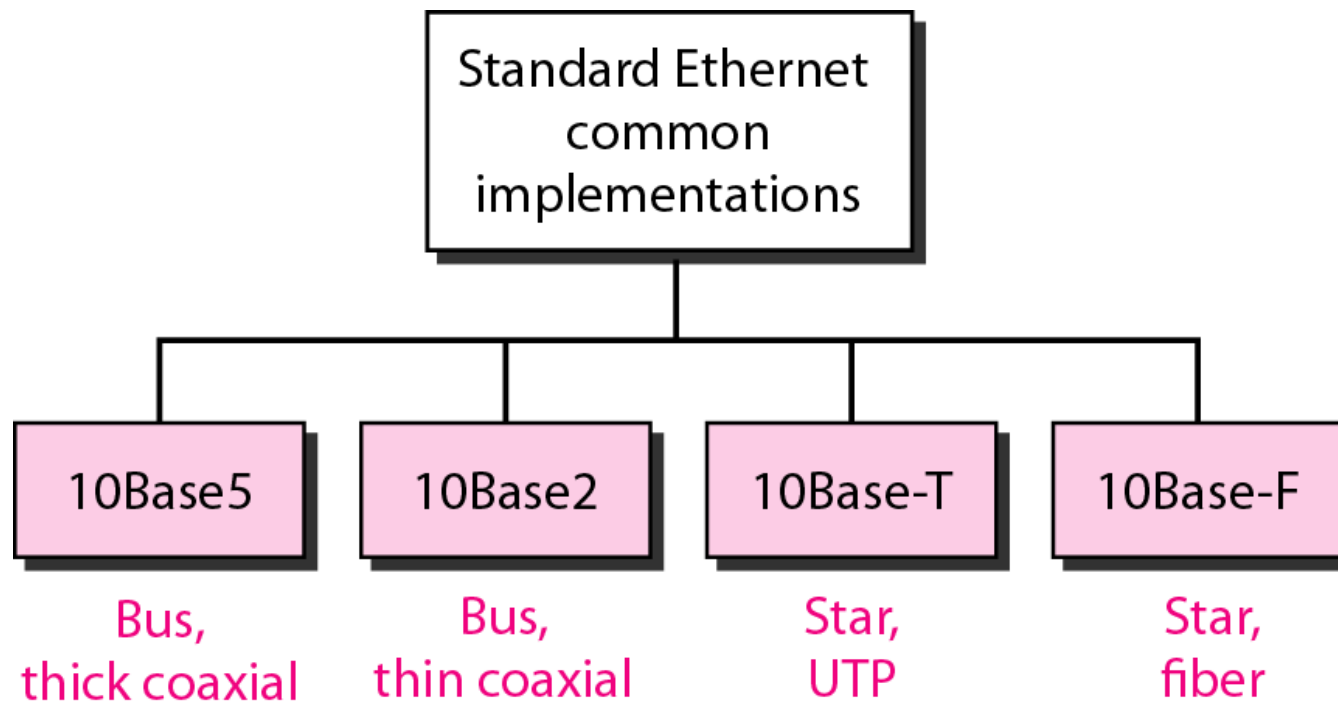



# 10Base5 implementation

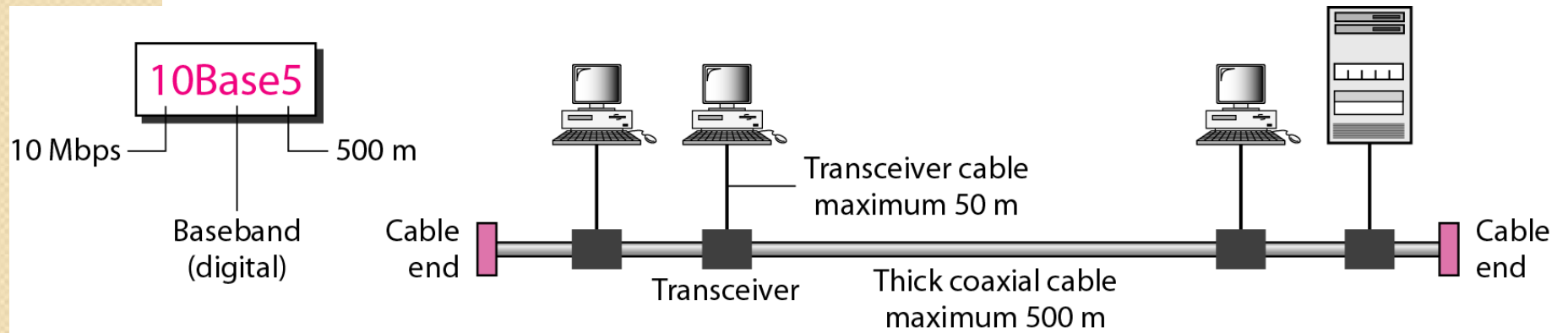

## 10Base2 implementation

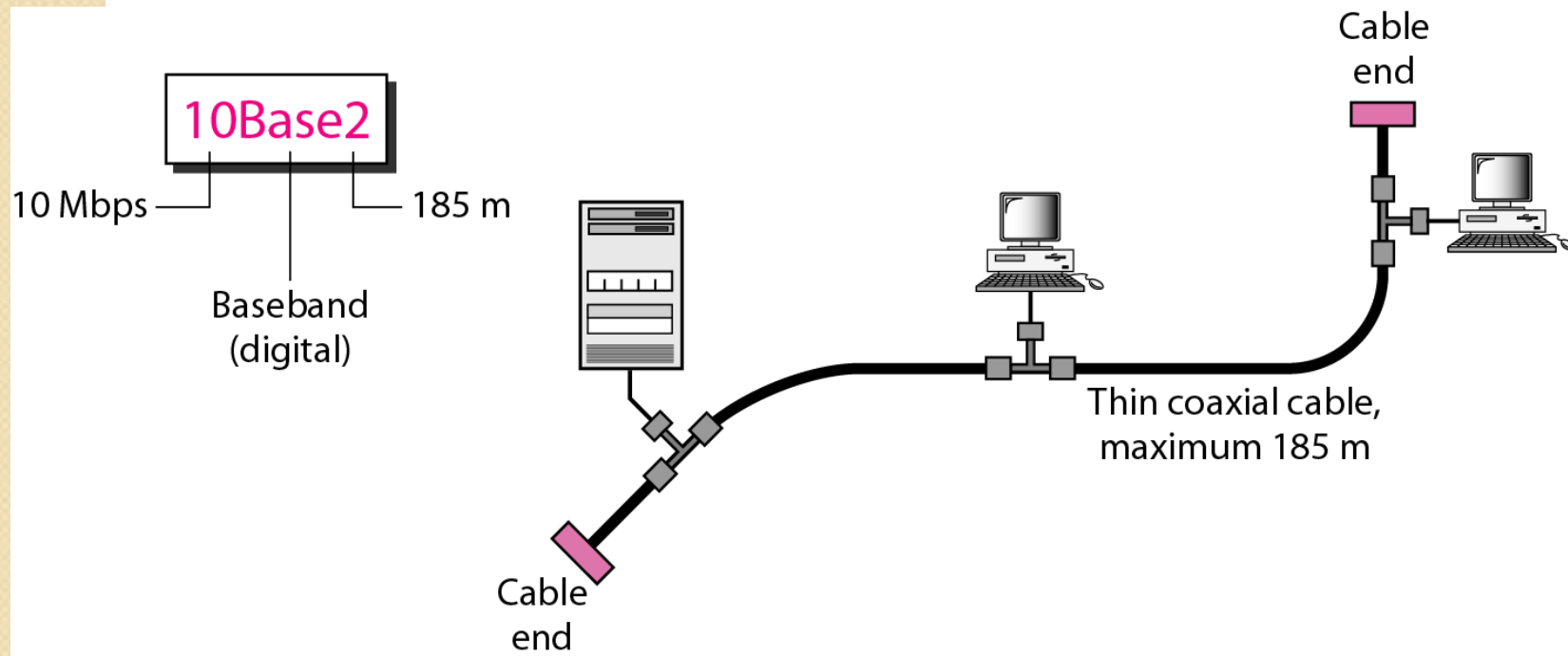

## 10Base-T implementation

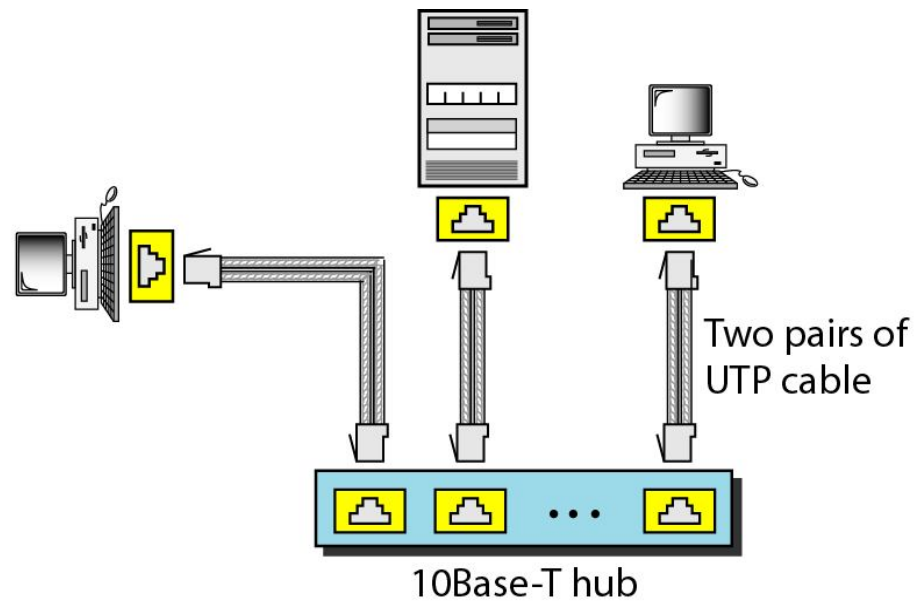
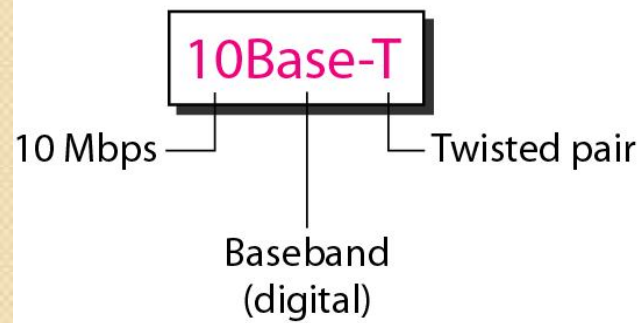

## 10Base-F implementation

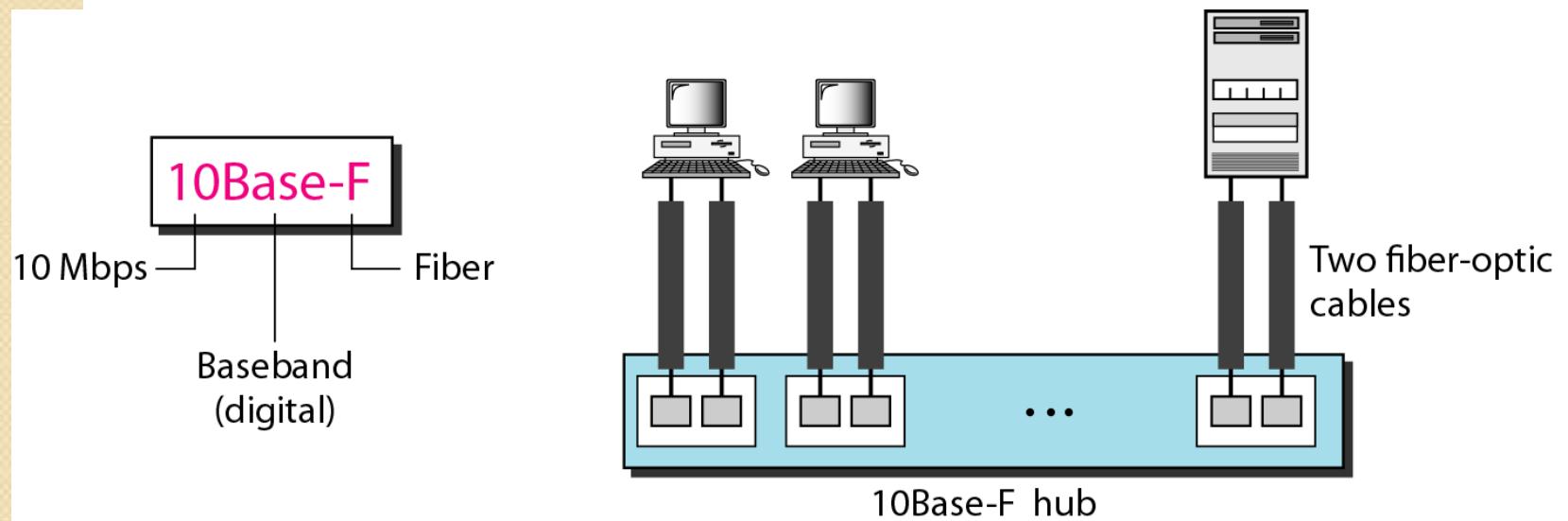

## CHANGES IN THE STANDARD

*The 10-Mbps Standard Ethernet has gone through several changes before moving to the higher data rates. These changes actually opened the road to the evolution of the Ethernet to become compatible with other high-data-rate LANs.*

- Bridged Ethernet
- Switched Ethernet
- Full-Duplex Ethernet

# BRIDGED ETHERNET

- Advantages
  - Raise bandwidth
  - Separate collision domains

## A network with and without a bridge

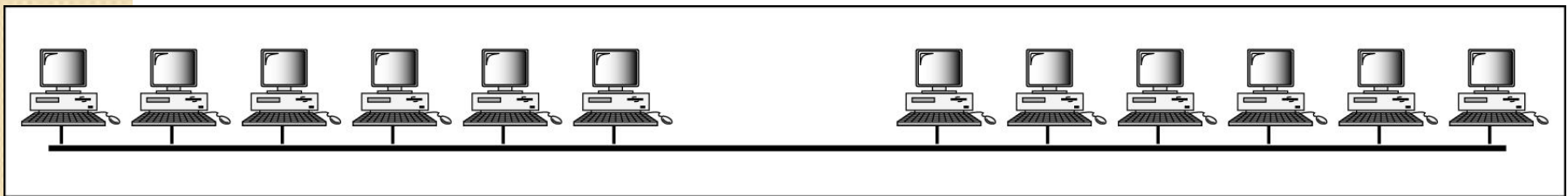

a. Without bridging

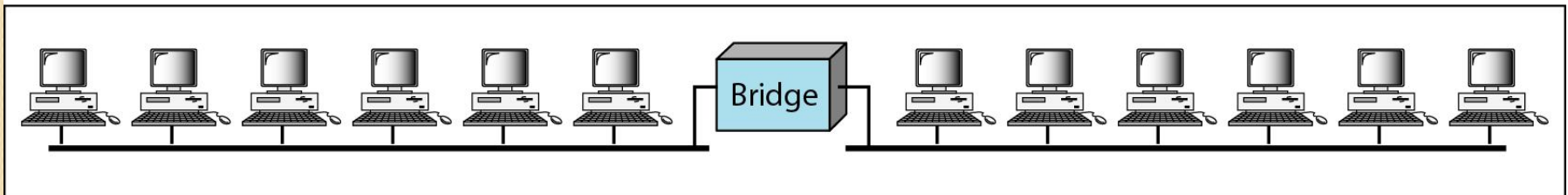

b. With bridging

# SWITCHED ETHERNET

- Better than bridged-Ethernet
- Reduced collision domain efficiently
- In this way, the bandwidth is shared only between the station and the switch



# Switched Ethernet

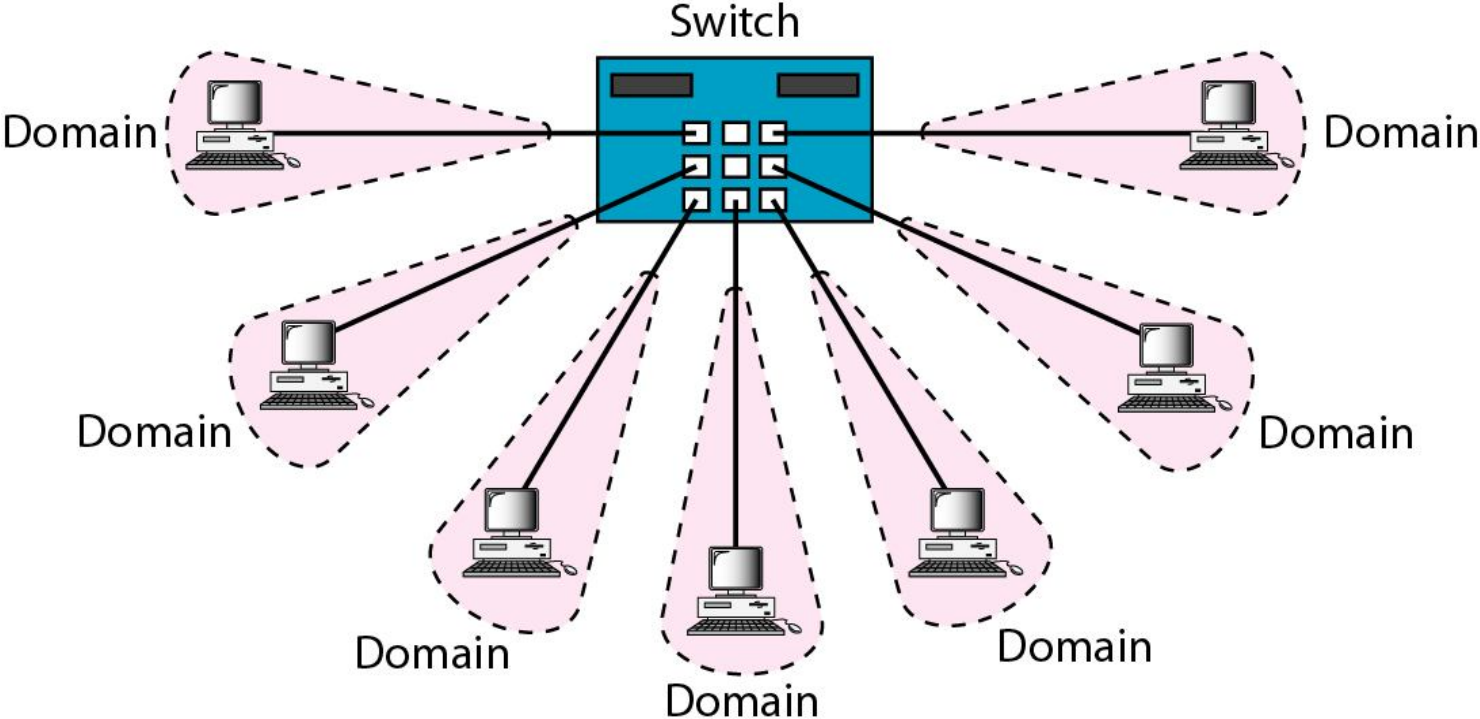

# FULL DUPLEX ETHERNET

- In 10Base5 and 2, a station can either send or receive, but may not do both at the same time.
- The next step in the evolution was to move from switched Ethernet to full-duplex switched Ethernet.
- The full-duplex mode increases the capacity of each domain from 10 – 20 Mbps.
- But in this config. It uses 2-links. One to transmit and one to receive. Refer the given fig.

Full-duplex switched Ethernet

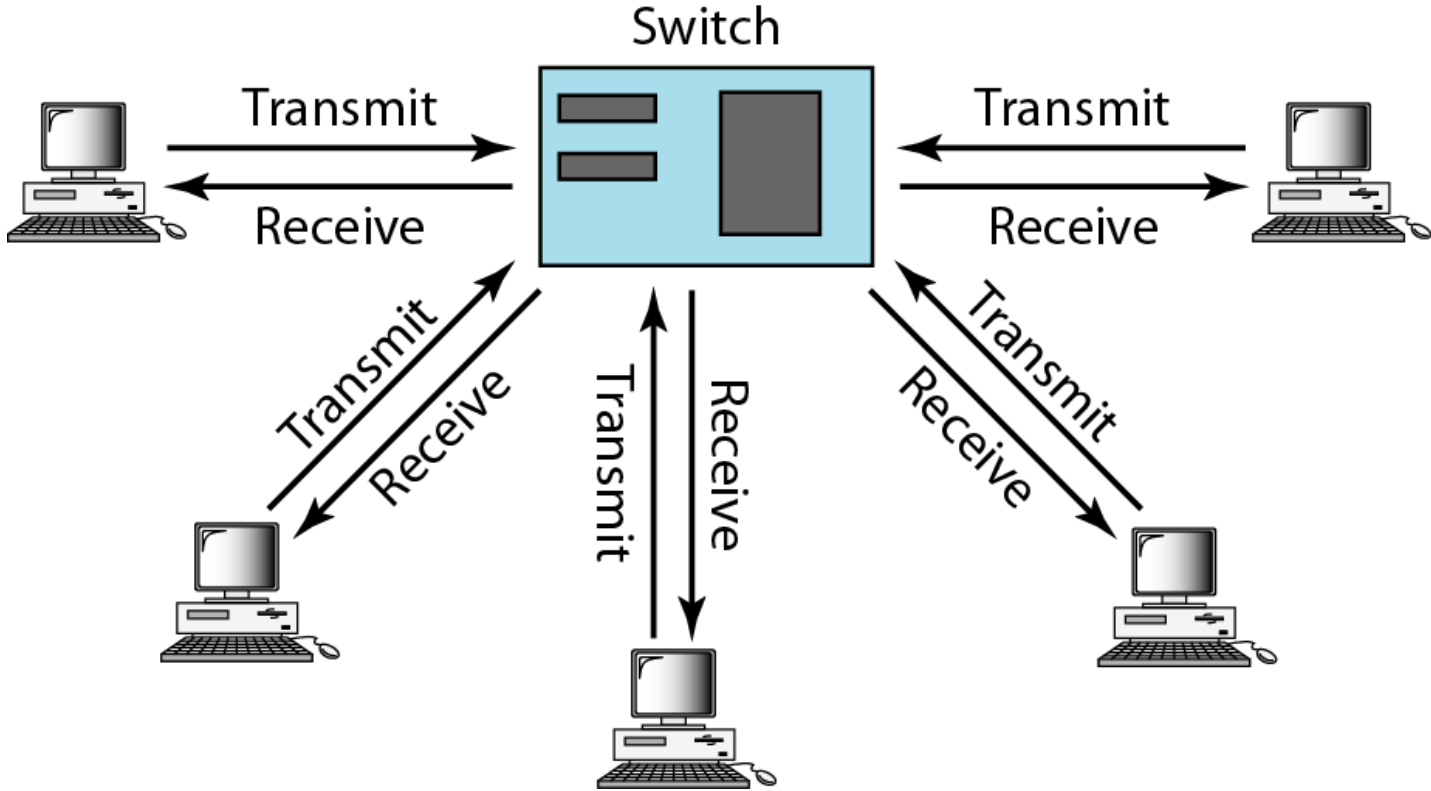

# FAST ETHERNET

*Fast Ethernet was designed to compete with LAN protocols such as FDDI or Fiber Channel. IEEE created Fast Ethernet under the name 802.3u. Fast Ethernet is backward-compatible with Standard Ethernet, but it can transmit data 10 times faster at a rate of 100 Mbps.*

---

## Fast Ethernet topology

---

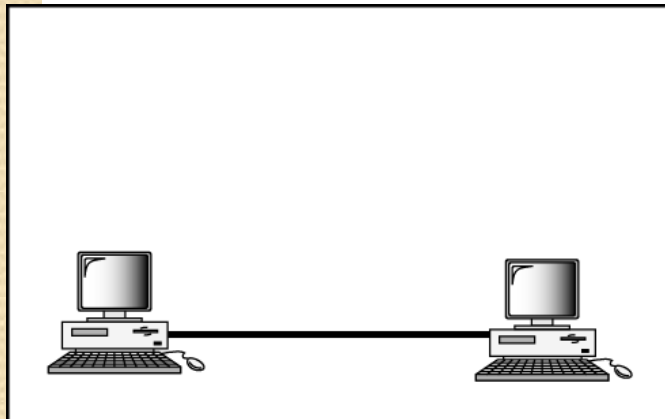

a. Point-to-point

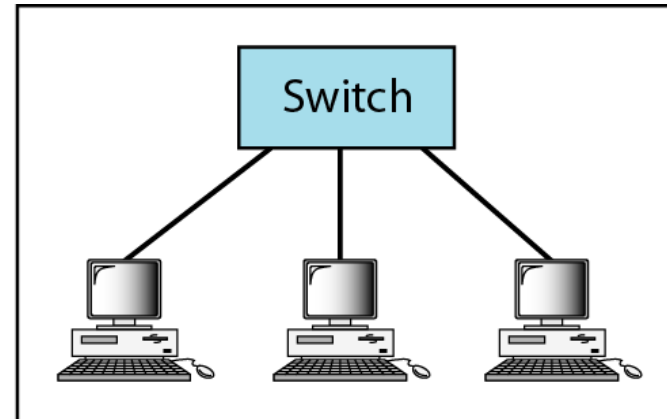

b. Star

---

## Fast Ethernet implementations

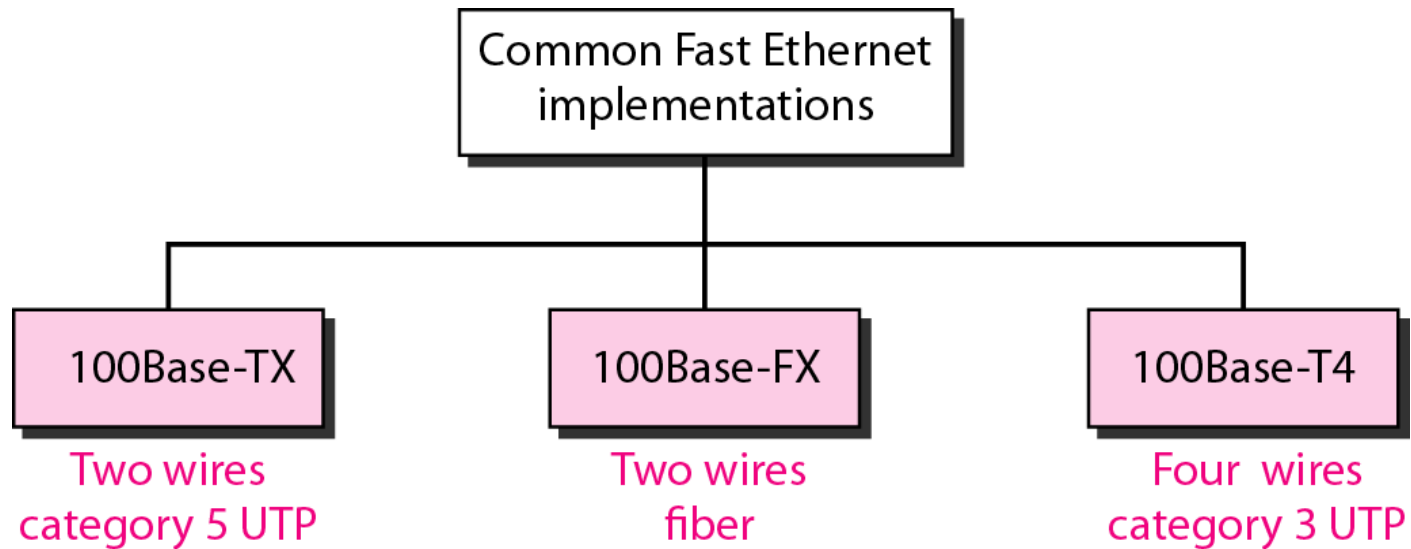

# GIGABIT ETHERNET

*The need for an even higher data rate resulted in the design of the Gigabit Ethernet protocol (1000 Mbps). The IEEE committee calls the standard 802.3z.*

# OBJECTIVES OF GIGABIT ETHERNET

- Upgrade the data rate to 1Gbps
- Make it compatible with standard or fast Ethernet
- Use the same 48-bit address
- Use the same frame format
- Keep the same minimum and max frame length
- To support auto negotiation as defined in fast Ethernet





*Note*

---

In the full-duplex mode of Gigabit Ethernet, there is no collision; the maximum length of the cable is determined by the signal attenuation in the cable.

---

# Topologies of Gigabit Ethernet

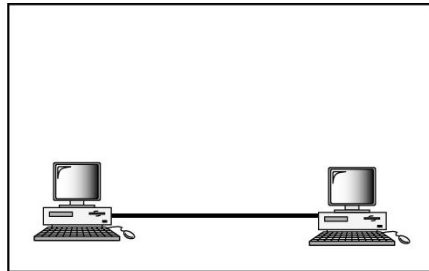

a. Point-to-point

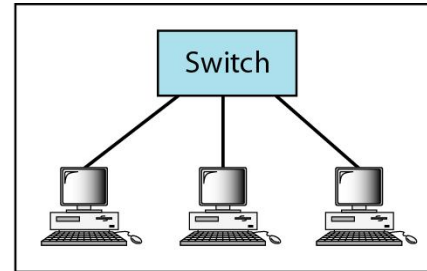

b. Star

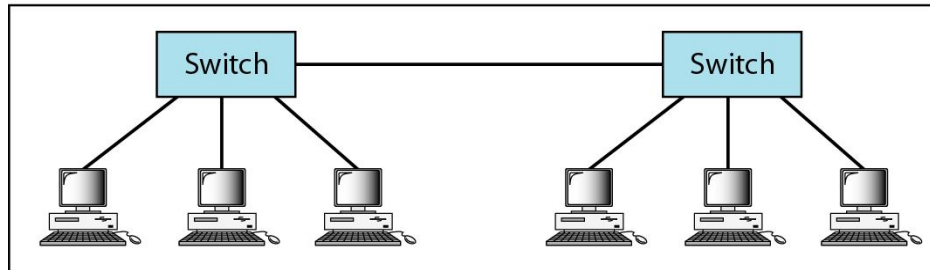

c. Two stars

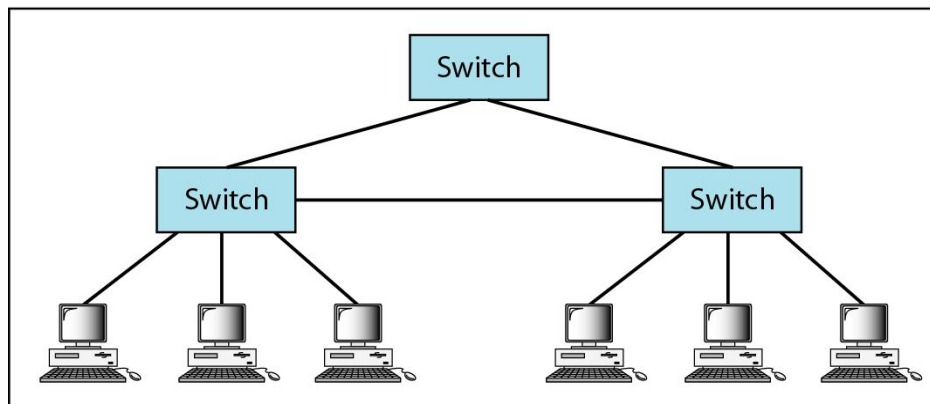

d. Hierarchy of stars

## Gigabit Ethernet implementations

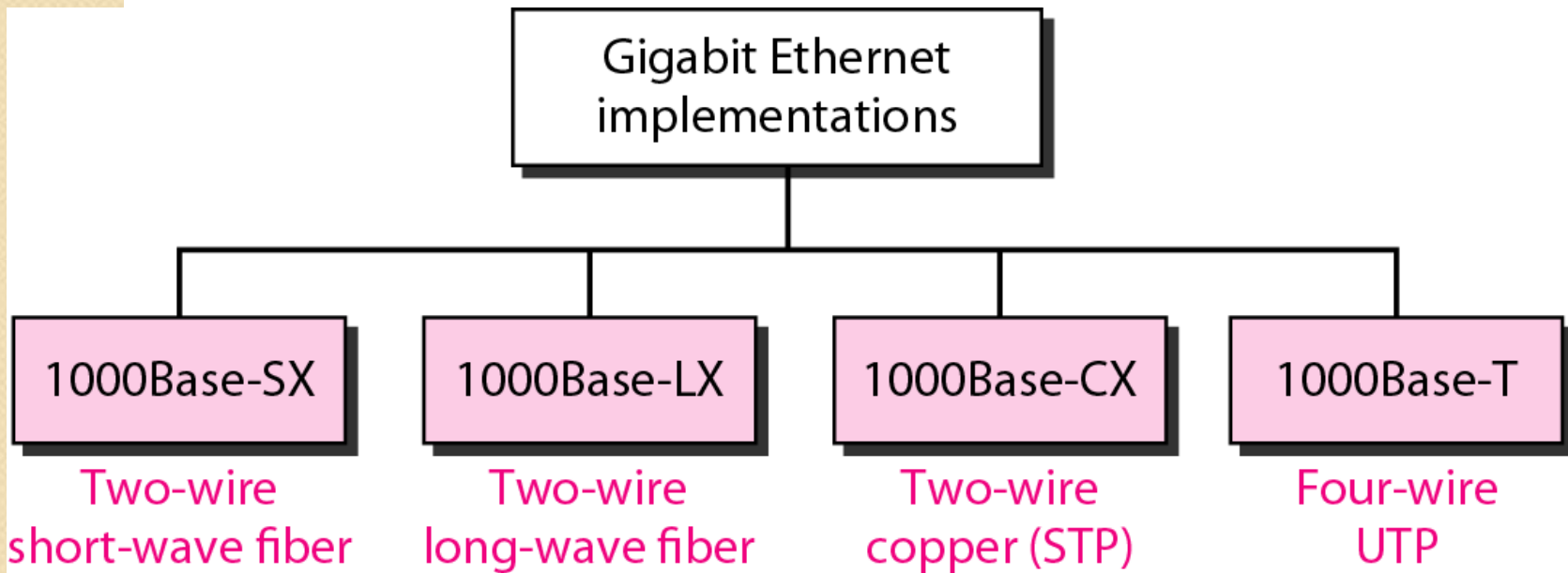



# Application

- Ethernet is used in Wired LAN's as a physical layer standard.
- All LANs based on Ethernet have Ethernet card in each of their nodes and nodes are connected through standard cabling supported by desired Ethernet LANs.
- Ethernet is giving higher data rates of 10Gigabits per second for Local area Networks.



# Scope of Research

- 10 Gigabit Ethernet and higher data rate Ethernets.

# Assignment

- Compare the implementations of Ethernet, Fast Ethernet and Gigabit Ethernet.